

PROteo

**PROteo**  
by **THEAULT**

SHARED PASSION





**Supreme performance, robust and elegant.  
Proteo, designed for the professional.**

New 2010



# PROteo

by THEAULT

## Proteo is practical

- Optimised locking systems for the doors and ramp. Easy to use with automatic closure.
- New version of our sliding partition with 7 positions makes adapting the horse space for comfort quick and easy.
- Enlarged ramp, spacious stalls with no central post. Proteo makes loading and unloading your horses safer and easier.

## Proteo and comfort

- Theault have followed the developments incorporated in the new Renault Master for improved soundproofing during transit and reduction of vibrations. A new level of comfort for passengers both human and equine.

## Proteo and economy

- By investing in a Theault horsebox you benefit from the reputation for quality that the brand has gained. An assured value with low depreciation.
- The most recent engines provide excellent fuel economy keeping costs low.
- Low cost maintenance.

## Proteo and design

- New, more spacious Luton provides greater storage space. The new rear panel with LED lights and horse tie bar (option) embedded for safety.

## Proteo and safety

- 5-seat cab homologated by UTAC insurable for up to 5 passengers.
- Rear door 1.2 metres wide available now in 3 formats. Easy access to your horses and equipment – An exit for your horses in case of emergency.
- Quick release breast bar assists easy exit of the horses in case of emergency.

## Proteo and the environment

Sensitive to the environment, Theault have produced the new Proteo to be as friendly to our planet as possible:

- Body construction of mainly recyclable materials.
- No toxic substances used in the construction of the body.
- The latest engines conforming to the new Euro 5 emissions standards.

## Proteo and flexibility

- 3 different versions and an extensive catalogue of options permit you to customise your Proteo to suit your individual requirements.
- Proteo is available with 3 or 5 seat cab and also as a stud version with chute stalling.

Conceived and built in France at our factory  
in the bay of the Mont Saint Michel



# PROteo

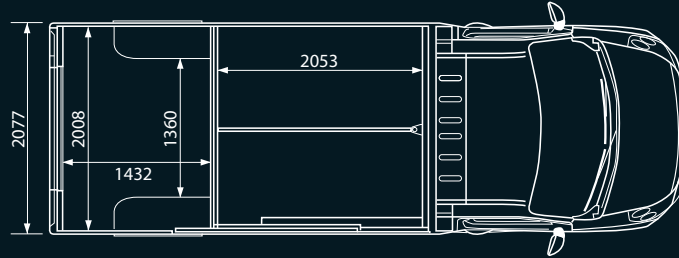

Protéo 3 SL

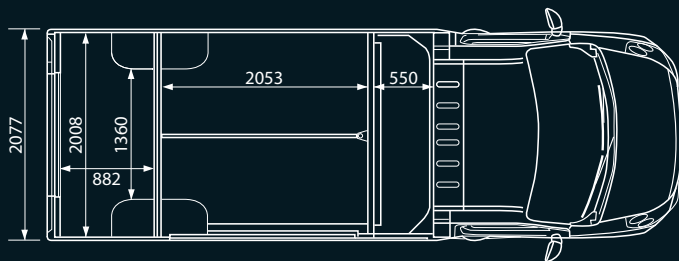

Protéo 5

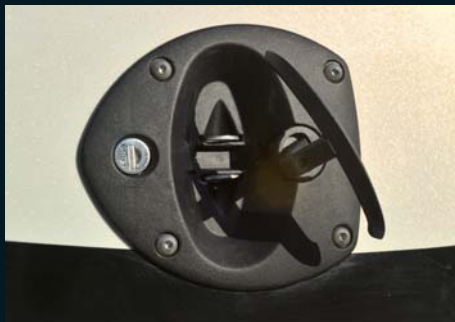



# PROteo Stud

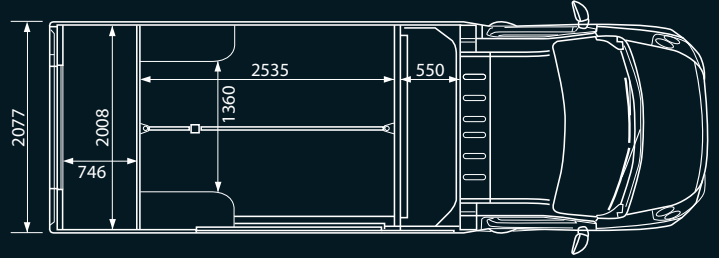

Protéo stud 5 L

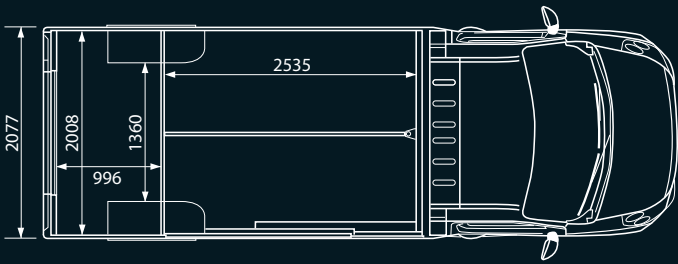

Protéo stud 3

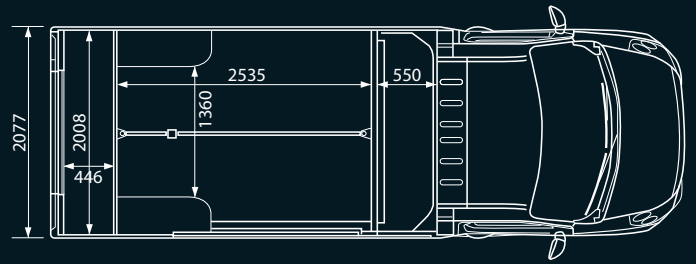

Protéo stud 5





SHARED PASSION



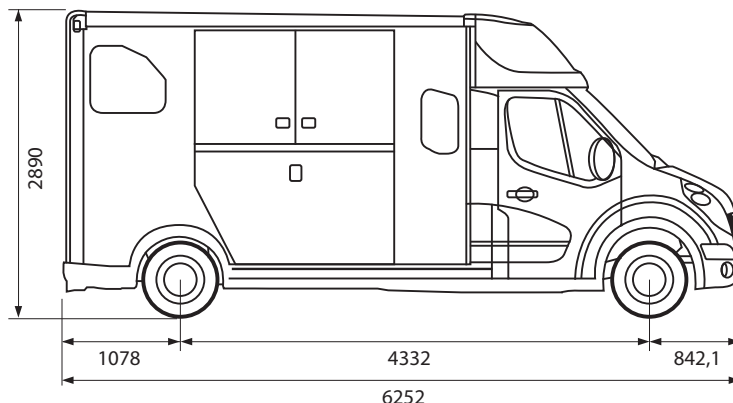
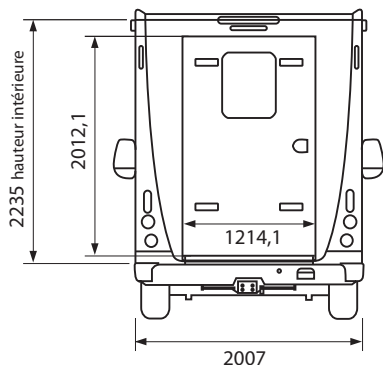

**PROteo 3 SL**

**PROteo 5**

**PROteo Stud 3**

**PROteo Stud 5**

**PROteo stud 5 L**

## Body

### ■ Standard Equipment:

Structure of 30mm aluminium sandwich panels – Shaped & insulated luton – aluminium side ramp – interior walls in horse area lined with rubber – 3 opening windows with protective grilles – rear door with 1 opening window – 1 roof skylight ventilator – 2 mechanical ventilators – electric air extractor – handles embedded in bodywork – external LED lights embedded in bodywork – Rear door 1.2 metres wide – exterior decoration of your choice.

### Options:

Fully body paint in colour of your choice – metallic body paint to match original colour of chassis – Painted bumper and accessories – reversing sensor – reversing camera.

## Cabin

### ■ Standard Equipment:

Engine 2.3L DCi 125hp (81kw) – ABS – Driver airbag – manual air conditioning – cruise control & computer – adjustable driver seat with lumbar support – 105L fuel tank – CD radio – LED lighting.

### Options:

150hp (107kw) engine – automatic gearbox – ESP – CD radio MP3 + Bluetooth + Plyg & Play – passenger airbag – adjustable passenger seat with lumbar support – Pacl climatic (automatic air conditioning, fog lamps, automatic headlamps) – access to the luton from the cab with bench converting to bunk beds – alloy wheels – rear air suspension – integrated Tom Tom satellite navigation – 3 part bench – leather upholstery – table – turning front seats – heated seats.

## Horse area

### ■ Standard Equipment:

Aluminium sliding partition with rubber skirt & 7 position settings (7 for Proteo with standard stalling; 3 with chute stalling) – Anti-slip rubber flooring in rear storage – Cibelastic flooring in horse area – white interior paint – interior & exterior tie-rings – quick-release breast bar with access doors – mountings for anti-weave grilles – protective padding – safety shell over wheelarches.

### Options:

Folding horse tie-bar – tow bar – saddle & bridle racks on rear door or side walls – sulky supports – protective shelf with mangers – range of tack lockers – surveillance camera – anti-weave grilles – temperature gauge.

**THEAULT** – BP 306 – Z.A de MAUDON – 50300 PONTS-SOUS-AVRANCHES

Tél: 33 (0)2 33 89 22 22 – Fax: 33 (0)2 33 89 22 42 – [infos@theault.fr](mailto:infos@theault.fr)



**Theault Austria**  
Pepo Puch  
+43 676 886 644 22

**Theault Australia**  
Kevin Blake  
+04 0156 5571

**Theault Belgium**  
Vanessa Magelinc  
+32 497 494 764

**Theault Czech Republic & Slovakia**  
Jan Hartman  
+420 776 072 306

**Theault Denmark**  
Bent Neergaard  
+45 4019 5300

**Theault Finland**  
Gun Järnefelt  
+ 358 405 513 523

**Theault Germany**  
Werner Hagstedt  
+49 170 475 67 80

**Theault Ireland**  
Claire Murphy  
+33 626 946 247

**Theault Italy**  
Serge Bruneau  
+39 348 584 22 57

**Theault Middle East**  
Nicolas Girof  
+971 506 244 308

**Theault Netherlands**  
Marco Dekker  
+31 654 386 920

**Theault Norway**  
Kristen Klekken  
+47 915 953 44

**Theault Portugal**  
Joao Sabino  
+351 917 244 459

**Theault Spain**  
Juan Carlos Lorenzo  
+34 606 215 073

**Theault Sweden**  
Ola Torstenson  
+46 705 296 178

**Theault Switzerland**  
Patrick Waeber  
+41 792 474 964

**Theault UK**  
Andrew Dolby  
+44 770 364 86 68

**International**  
Vanessa Gau  
+33 677 981 052